



# CASTRO

ENTERTAINMENT



# PANTALLA LED

## P3 INDOOR SMD 3IN1 TECHNICAL PARAMETERS



## P3.91 INDOOR SMD 3IN1 TECHNICAL PARAMETERS

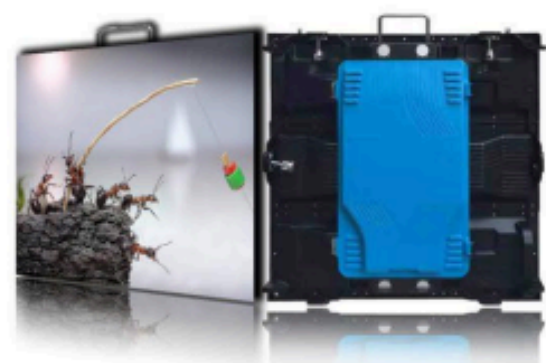
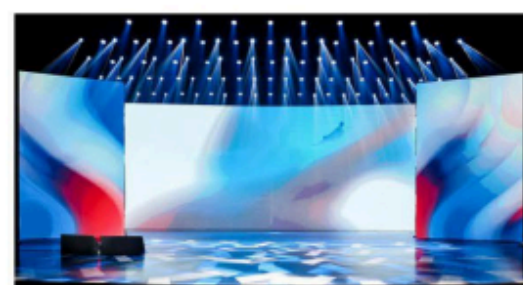

Item	Parameter
Model Number	P3-32S
Module size	192mm*192mm
Pixel pitch	3mm
Pixels Density	111111 dots/m <sup>2</sup>
Pixel configuration	1R1G1B
Package mode	SMD2121
Pixel resolution	64dots(W)*64 dots(H)
Drive type	Constant drive (IC:2037/2153)
Refresh frequency	≥1920/3840HZ
Scan mode	1/32 scan
Port type	HUB75
Brightness of white balance	≥1200-1500cd/m <sup>2</sup>

Item	Parameter
Model Number	P3.91-16S
Module size	250mm*250mm
Pixel pitch	3.91mm
Pixels Density	65536 dots/m <sup>2</sup>
Pixel configuration	1R1G1B
Package mode	SMD2121
Pixel resolution	64dots(W)*64 dots(H)
Drive type	Constant drive (IC:2038S/2153)
Refresh frequency	≥1920/3840HZ
Scan mode	1/16 scan
Port type	HUB75

# PANTALLA LED

## INDOOR P2 SMD 3IN1 TECHNICAL PARAMETERS



	Item	Parameter
Unit Module	Model Number	P2-40S
	Module size	320mm*160mm
	Pixel pitch	2mm
	Pixels Density	250000 dots/m <sup>2</sup>
	Pixel configuration	1R1G1B
	Package mode	SMD1515
	Pixel resolution	160dots(W)*80dots(H)
	Drive type	Constant drive 2037/2153
	Scan mode	1/40 scan
	Port type	HUB75
	Brightness of white balance	≥ 1200cd/m <sup>2</sup>
	Screen	Cabinet size
Display size		640*1920mm
Module quantity		24pcs
Power supply quantity		6pcs 300W5V60A
Density		307200 dots/pcs
Control		Wi-Fi /USB/Mobile phone(APP)/iPad/RJ45
Weight		48KG
Packing		Wooden box

## P3.91 OUTDOOR SMD 3IN1 TECHNICAL PARAMETERS



Item	Parameter
Model Number	P3.91-16S
Module size	250mm*250mm
Pixel pitch	3.91mm
Pixels Density	65536 dots/m <sup>2</sup>
Pixel configuration	1R1G1B
Package mode	SMD1921
Pixel resolution	64dots(W)*64 dots(H)
Drive type	Constant drive (IC:2038S/2153)
Refresh frequency	≥ 1920/3840HZ
Scan mode	1/16 scan
Port type	HUB75
Brightness of white balance	≥ 5500-6500mcd

# PANTALLA LED

## P5 OUTDOOR SMD 3IN1 TECHNICAL PARAMETERS



Item	Parameter
Model Number	P5-8S
Module size	320mm*160mm
Pixel pitch	5mm
Pixels Density	40000 dots/m <sup>2</sup>
Pixel configuration	1R1G1B
Package mode	SMD1921
Pixel resolution	64dots(W)*32 dots(H)
Drive type	Constant drive (IC:2037/2153)
Refresh frequency	≥1920/3840HZ
Scan mode	1/8 scan
Port type	HUB75
Brightness of white balance	≥5500-6500mcd

# EQUIPO DE ILUMINACIÓN

## CW-380W 3IN1 MOVING HEAD LIGHT



### TECHNICAL PARAMETER

Light source: PHILIPS 19R  
Voltage: AC110-240V, 50/60Hz, power: 470W  
Display: 2.8-inch touch screen, 180° reverse  
Color disc: 14 color chips+white light;  
Fixed pattern plate: 14 patterns+white light;  
Prism: 16+32 prism, prism can be superimposed, light angle: 2°  
Dimming: 0-100% mechanical dimming, supporting mechanical stroboscopic and adjustable speed  
Stroboscopic effect, support stroboscopic macro function, lens group optical system  
The photoelectric reset system can automatically retrieve and reset after misoperation;  
Positioning technology: adopt magnetoelectric positioning system and use magnetic components  
It replaces the traditional Hall positioning system with higher accuracy and reliable performance.  
USB: It supports unplugging the address code in the case of no power supply.  
It can be used to make software and upgrade the external interface  
Horizontal: 540° , vertical: 270°  
IP protection grade: IP20;  
Product size: 424mm x 390mm x 622mm  
Package size: 930mmx500mmx840mm (air box)  
Net weight: 23 kg  
Gross weight: 26.5kg

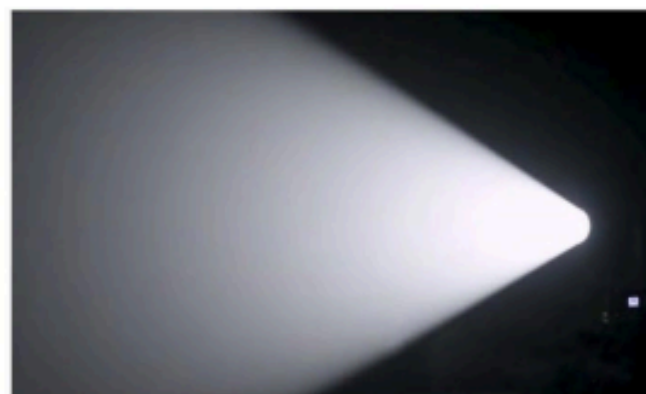

## CW-380B BEAM MOVING HEAD LIGHT



### DIMENSION(MM)



### TECHNICAL PARAMETER

Voltage: AC 110-240V 50/60Hz  
Power: 530W  
Fuse: 7A  
Ballast: Electronic ballast  
Light source: Bulb  
Light power: 380W  
Color temperature: 7800K  
Average life: 1500H (bulb and reflector are packaged as a whole, with higher light efficiency and longer service life)  
Number of motors: a total of 14 silent motors, XY three-phase motors  
Dimming: 0-100% linear adjustment.  
Fixed color: 14 color chips + white light (half-color effect possible)  
Static patterns: 11 fixed pictures + white light + 3 glass patterns  
Prism: 8+8+8 honeycomb prism, 8+16 prism (double prism can be superimposed 48, can be rotated independently in both directions)  
Color film: 1 six-color film (can do colorful effect)  
Atomization: 1 independent atomization effect, soft and natural light spot  
Control channel: 18CH  
Size: 32 x 22 x 58cm (LxWxH)  
Control signal: International standard DMX512  
Appearance: high temperature resistant plastic  
Light body color: Black  
Protection level: IP20  
Net weight: 15.5kg

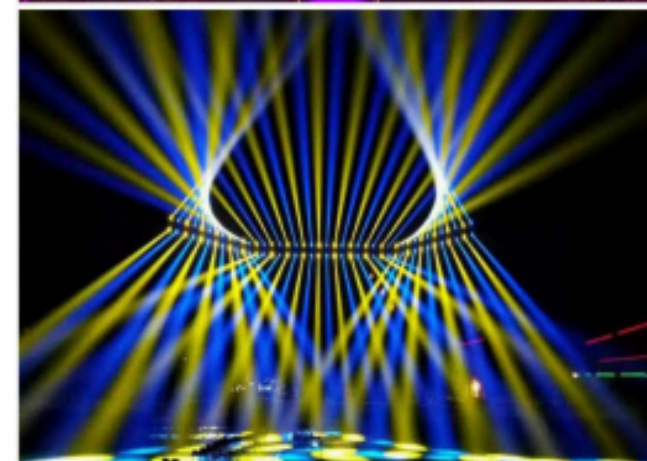

# EQUIPO DE ILUMINACIÓN

## CW-260 BEAM MOVING HEAD LIGHT



### DIMENSION(MM)



### TECHNICAL PARAMETER

Voltage: AC110-240V 50/60HZ  
 Light source: YODN 260  
 Channel: 17CH  
 Color disc: 13 colors + white, With a rotating rainbow effect  
 Pattern: 13 pictures + white, With rotating gradient effect and pattern swinging effect.  
 Flash: 13 times/second, with random pulse stroboscopic function  
 Dimming: 0-100% linear adjustment  
 Focus: 5 meters to infinity  
 Prisms: standard 16+8 honeycomb prisms and single 16 prisms (provide three or multi-layer prisms and single-layer prisms for customer selection)  
 Colorful: equipped with a multicolored disk, can play a colorful beam effect and colorful prism effect  
 Atomization: 0-100% linear atomization  
 Pan: 540° (scan) 16 bit precision electronic error correction  
 Tilt: 250 pixels (16bit precision scanning) electronic error correction  
 Control desk reset function, control switch bubble function, color half color function  
 Illumination: 12m 200000LUX(light over conventional 350 beam lamp)  
 Lamp body size: 330\*230\*590mm  
 Net weight: 15 kg

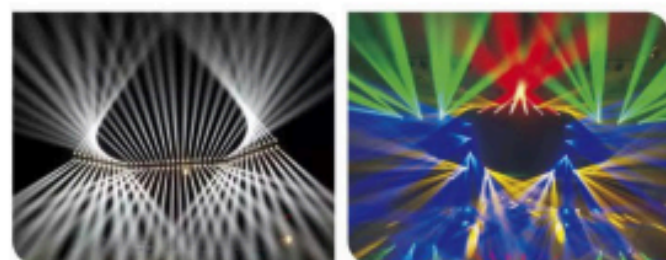

Channel	Function
1	Pan
2	Tilt
3	Pan/Tilt Speed
4	Shutter
5	Dimmer
6	Color
7	Gobo
8	Prism
9	Prism Rotation
10	Focus
11	Zoom(Empty)
12	Frost
13	Pan 16 bit
14	Tilt 16 bit
15	Lamp ON/OFF
16	Reset



## CW-250 BEAM MOVING HEAD LIGHT



### Color wheel



### DIMENSION(MM)



### TECHNICAL PARAMETER

Power Supply: AC110v-240V 50/60hz  
 Power: 300W  
 Light source: 250W Lamp  
 Ballast: electronic ballast  
 Housing: ABS plastic+alloy  
 Color: Black  
 Beam angle parallel beam angel :0-3.8°  
 Channel: 16/14ch  
 Working lifetime(Hour): 2000Hs  
 N.W.: 13.68KG

### Specification:

Dimmer: Independent dimmer channel, 0-100% linear dimmer  
 Strobe: Independent strobe channel, 1-13times/s, speed adjustable  
 Prism: Prism 1: 16 prism rotation;  
 Prism 2: 8+16 Prism rotation, 2prism can overlap.  
 1 colorful wheel: six color  
 Gobo: 14 gobos+blank double rotation rainbow effect  
 Colors: 13 color+blank, single rotation rainbow effect  
 Focus: option focus  
 Mode of control: DMX512/Master-slave/Sound/Stand-alone /Auto  
 Pan: 540degree (16bit) Electric correction  
 Tilt: 270degree (16bit) Electric correction  
 DM 3-pin IN/OUT  
 PowerCon IN  
 Display: Blue LCD display  
 Lamp: LAMP DMX ON/OFF, ignited by inverter, protect and lengthen the lifetime of the bulb



1	1	Pan
2	2	Tilt
3	3	X/Y Speed
4	4	Shutter
5	5	Strobe
6	6	Color
7	7	Gobo
8	8	Prism
9	9	Prism rotation
10	10	Focus
11	11	Enlarge
12	12	Frost
13		X Fine
14		Y Fine
15	13	Lamp on/off
16	14	Reset

# EQUIPO DE ILUMINACIÓN

## CW-200/ CW-230 BEAM MOVING HEAD LIGHT



### Gobo and Color wheel



### TECHNICAL PARAMETER

Voltage: AC110-240V by Switch 50-60Hz  
 Power Consumption: 300W  
 Light Source: 7R Platinum OSRAM Lamp  
 Color Temperature: 8000K  
 Ballast: Electronics ballast  
 Motor: Three phase or two phase motor can be choosed  
 Color Wheel: One with 14 colors+white  
 With adjustable rotation speed  
 With double direction stream and rainbow effect  
 With color location  
 Fixed Gobo Wheel,With 17 gobos+open  
 With double direction rotation  
 With sharking effect With adjustable rotating speed  
 Prism: With 8-facet prism  
 With double direction rotation  
 With adjustable rotation speed  
 Focus: Linear focus from close to far  
 Frost: With frost effect  
 With frost adjustable speed  
 Strobe: Mechanical Strobe 1-12 F.P.S  
 With adjustable strobe speed  
 With wonderful strobe style  
 Movement: Pan0-540° /Tilt 0-270°  
 With Pan/Tilt fine function Auto correction function  
 Hall location 16 Bit  
 Control: 16/20CH  
 LCD display  
 High temperature protection  
 Size: 452x445x540mm

### DIMENSION(MM)



1	Pan
2	Tilt
3	X/Y Speed
4	Shutter
5	Strobe
6	Color
7	Gobo
8	Prism
9	Prism rotation
10	Focus
11	Enlarge
12	Frost
13	X Fine
14	Y Fine
15	Lamp on/off
16	Reset

## BIG BEE EYE 19PCS\*15W LED MOVING HEAD WITH ZOOM



Voltage:AC100-240V,50-60Hz  
 Power consumption:300W  
 Source:19pcs 15W RGBW 4 in 1 LEDs  
 Control Mode:DMX512,Master-slave,Auto,Sound  
 Beam angle:6°  
 Strobe:0-25Hz  
 Color:RGBW infinite color mixture system  
 Channel:18CH  
 Working Temperature:-25° C-40° C  
 Working Lifetime:5,000hours  
 Scan range: Pan:540° , Tilt:270°  
 IP rate:IP20(Indoor use only)  
 Packing size:494\*358\*253mm  
 N.W.:15kg

## 19PCS\*15W LED MOVING HEAD ZOOM

Main LED: 19pcs 15W high brightness RGBW 4-in-1 LED  
 Backlight LED: 30pcs 0.18W RGB 3-in-1 LED  
 Channel: 14/25CH  
 Control: DMX512/Master-slave/Auto/Sound  
 Strobe: 1-25 times/second  
 PAN: 540 degree,Tilt: 270 degree  
 Beam angle: 8-50 degrees  
 Color: RGBW infinite mixture  
 Dimmer: 0-100% linear dimming system  
 Display: LCD display  
 IP20 protection rating  
 3-Pin XLR DMX input/output  
 Net Weight: 7.7 Kg  
 Gross Weight: 9.5 Kg  
 Carton Package Size: 38\*26\*47.5 cm

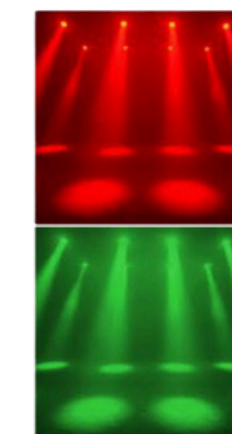

## 37PCS\*15W LED MOVING HEAD WITH ZOOM

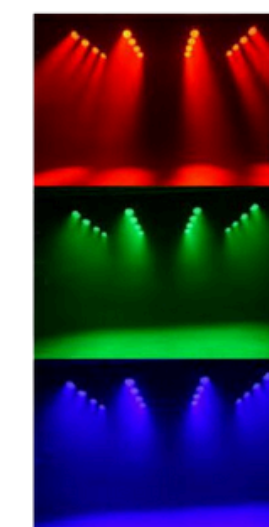

Voltage: AC 100-240V, 50/60Hz  
 Power Consumption: 704W  
 LED Source: 37 X15W Pro light LED  
 Beam Angel: 10° ~ 60°  
 DMX Channels: 14/26 channels mode  
 Blue white LCD display for easy navigation  
 Power Cable Daisy Chain: 9 Fixture Max. (230V, 50Hz)  
 5 Fixture Max. (120V, 60Hz)  
 Extremely small, fast and powerful LED moving beam.  
 Outstanding color macro effect, variable strobe effects  
 Perfect for stage, theatre, TV studio,  
 rental and discotheques  
 Light Size: 43X24.6X51.2cm  
 Weight: 19.5Kg

# EQUIPO DE ILUMINACIÓN

## CW-W2403 18/24pcs\*1/3W LED Wall washer light



Input Voltage: AC180V~256V  
 Power Consumption: 24W/72W  
 Source: 1W/3W LED 24pcs Colorful Optional  
 Beam angle: 35°  
 Project distance: 20m  
 Source life: 50000 hours  
 Control system: DMX 512 control  
 DMX Channel: 7 Channels  
 Connection: 3 pins XLR-sockets  
 Operating Voltage: 18VDC 320mA ± 5%  
 Protection rating: IP65  
 Operating temperature: Range -18° C ~ +40° C (0° F ~ +104° F)  
 Storage temperature: Range 5° C ~ +30° C (41° F ~ +86° F)  
 Tilt Rotary angle: 175° Housing: Aluminum alloy  
 Size: L100xW7.6xH10cm Weight: 4kg

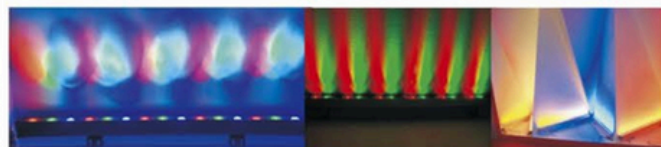

## CW-2510A 5\*5 LED Matrix Wash

Voltage: AC110-240V/50-60Hz  
 Power: 800W  
 Source: Lumi Engin 30Wx25pcs LED 4 in 1  
 Dimmer: 0-100%  
 Strobe: 0-27Hz  
 Control channel: 8CH/80CH  
 Control Mode: DMX512, Master-Slave, Sound, Auto  
 Display: Digital display screen  
 Carton Size: 66x65x23cm  
 N.W.: 16kg  
 G.W.: 18kg



## CW-S960B 1000W/3000W RGB LED Strobe Light

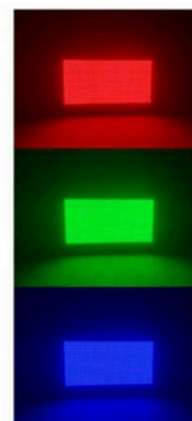

Voltage: AC110-240V 50-60Hz  
 Total power: 1000W  
 Color temperature: 6500-7500K  
 Source: 960pcsx1.2W SMD5050 LED  
 Light source life: More than 50,000 hours  
 Dimming: 0-100% linear adjustment  
 Emission color: RGB  
 Body: Aluminum  
 Data connection: 3-pin5-pinXLR input/output  
 Strobe: 1-30HZ regular strobe, random strobe, pulse strobe  
 Mode: DMX512, Master-slave, Sound, Auto  
 Applicable: Dimming, Strobe, Red/Green/Blue Macro, Macro Speed  
 Channel: 8CH  
 Product size: 500x275x140mm  
 Carton size: 540x320x205mm  
 N.W.: 7.5kg  
 G.W.: 8.0kg

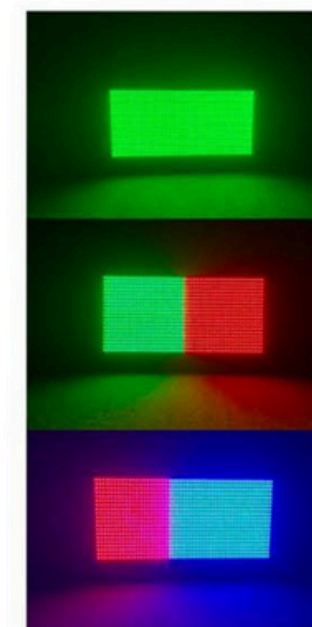

## CW-S864 8+8 Segment Strobe Light

Voltage: AC100-240V 50/60Hz  
 Power: 38V/280W  
 Source: 864pcs 5050RGB LED+96pcs white LEDs  
 Mode: DMX512, Auto, Master-slave, Sound, RDM  
 Channel: 4/11/12/32/39CH  
 Dimming: 32bit 0-100% linear dimming  
 Features: 8+8 sections of horse racing+dyeing+flash  
 Working temperature: -30° C - 50° C  
 Strobe: 1-30HZ  
 Appearance: Metal, Black  
 Connection method: DMX512 input/output  
 Power input/output  
 IP grade: IP20  
 Size: 445 \* 215 \* 140MM  
 Gross weight: 6.5KG

## CW-LM1083 108pcs LED Wash Moving Head

Voltage: AC100-240V  
 Frequency: 50/60Hz  
 Power consumption: 380W  
 Light source type: LED  
 Light source power: 108 \* 3W RGBW  
 Flare Angle: 25°  
 Control mode: DMX512  
 The control channel: 14/18 channel  
 Scanning Angle: 540° (level), 540° (vertical)  
 Operation mode: Master-slave/Sound/Auto  
 Dimmer Stroboscopic:  
 Highly electronic dimmer, strobe can reach 1-20t/s  
 Color: RGB color mixture evenly system  
 and rainbow effect (additive white)





# EQUIPO DE ILUMINACIÓN

CW-FP5403  
54pcs LED Waterproof Par



Input voltage: 220V 50–60Hz  
Output voltage: 28V  
Power: 200W  
Source: 3Wx54 high brightness LED  
(R12, G14, B14, W14)  
Beam angle: 25 ° / 38 ° / 60 ° (Optional)  
Color: RGBW color mixing colors  
Strobe: 0.05–5 times / sec  
Control: Standard DMX512 signal  
Channel: 8CH  
Waterproof: IP67  
Size: 340x300x290mm  
N.W.: 9.5kg

CW-P5403B  
54pcs\*3W LED Color Par



Voltage:AC220V/50Hz  
Source:54pcs\*3W High-brightness LED  
(R12,G18,B18,W6)  
Lamp life:6–10 million hours  
Beam angle:25°  
Mode: DMX512,Master/Slave,Auto,Sound  
Function:Colour mixing,Choose color,  
Jumping,Flash run  
Control channel:8CH(Digital display)  
Size:197\*130\*240mm  
Weight:1.5kg

CW-4100  
LED 4 Eyes Blinder Light



Voltage:AC90–240V 50–60Hz  
Power:450W  
Source:4pcs 100W COB LED  
Color:WW+W,W,WW  
Color Temp.:3000K–7000K adjustable  
Light life:6–10 ten thousand Hours  
Mode:DMX512,Master-slave,Auto  
Channel:2/4/7 CH  
IP Rate:IP20,Fan cooling  
Size:420x120x190mm(LxWxH)  
N.W.:8kg  
G.W.:9.5kg

# EQUIPO DE ILUMINACIÓN

CW-J3

10W/5W/3W/2W/1.5W Fullcolor Laser



Voltage: Bi-voltage 110V-220V-250V,50/60Hz,Power: 50W  
Scanner: 40Kpss bragon Tiger High-speed optical,  
big angle scanning(0-30°)Optional 30K  
Laser: Green:500mW 532nm,TE-cooled  
Red:500mW 638nm,TE-cooled  
Blue:2000mW 445nm  
Mixed white laser 3000mW laser tube import from Germany  
Control Mode: Sound Active,auto-beam,  
auto-animation,DMX,Master/Slave,PC  
Control DMX channel: 12CH  
PC Control: Compatible ILDA laser show software with ILDA interface,  
Use electronic switches to conversion full ILDA signal  
Safe capacity: Design according to security and good performance,  
safer to human and environment,master/slave mode,  
DMX512 mode and PC control mode,will shut off laser  
automatically without trigger signal



## CW-F350W 350W 17R Follow Light

Support voltage:AC220V~240V 50Hz/60Hz  
Electricity power:430W/450W  
Bulb specifications:330W/350W PHILIPS Lamp  
Colours:Colour wheel 6 kinds of color  
+ Three color temperature  
Control signal:Participate of control box  
Control mode:Stand-alone mode  
Cooling system:High strength air-cooled  
Aperture effect:Aperture size is adjustable  
Stroboscopic: stroboscopic 1-7 times/SEC  
Color temperature correction:  
Normal 5600K,Max6000K,Min3200K  
Speed of light distance: 80-100m  
Speed of light Angle: 23 degrees  
Security measures: the various security standard,  
IP20 protection level,Power cord CE20/22 level  
3 standard,The high temperature cut off protection device  
Outer shell: aluminum alloy  
Size:72\*35.5\*30.5cm Weight:19KG



## CW-F330 330W LED Follow Light

Support voltage:AC220V~240V 50Hz/60Hz  
Electricity power:380W/750W  
Bulb specifications:LED 330W/350W  
Colours:Colour wheel 4 kinds of color + white light,  
Gobo can be determined  
Control signal:Mixed signals, control knob  
Control mode:Stand-alone mode  
Optical system:US LUMENS LED  
Cooling system:High strength air-cooled  
Aperture effect:Aperture size is adjustable  
Stroboscopic: stroboscopic 1-7 times/SEC  
Color temperature correction:Normal 5600K,Max6000K,Min3200K  
Speed of light distance: 30-60m  
Speed of light Angle: 23 degrees  
Security measures: the various security standard,  
IP20 protection level,Power cord CE20/22 level  
3 standard,The high temperature cut off protection device  
Outer shell: aluminum alloy  
Size:70\*35\*45cm Weight:7KG

# CONSOLAS

## CW-KQ4512 Quartz Console



14.1-inch screen, 9.1 10.0 10.1 11.0 11.1  
Five-system free switching system with ups power supply  
The default output is 4 512, the network can output 12 512  
Intel Core I5 processor, 120G solid state hard disk,  
4GB running memory, 90 minutes ups power.  
Built-in 4 DMX output ports, 2048 channels;  
Support Art-net network output, which can be expanded  
to 12 Universe DMX outputs through the network;  
Support Titan-net protocol, expandable to  
64 Universe DMX outputs  
10 mechanical page turning playback faders;  
20 custom macro function keys  
Built-in 14.1-inch highlight touch screen,  
which can be extended by a Titan Fader wing  
20 playback faders,30 custom macro functions,USB powered  
Support headphone output  
1 Gigabit network interface, support Art-net, Titan-net,  
Streaming CAN protocols  
Compatible with other TITAN system console performance files  
Carton size: 59 \* 54 \* 29 Carton weight: 13.3KG  
Air box size: 59 \* 54 \* 35.5 Air box weight: 22.8KG

## CW-T2048 Tiger Touch II Console DMX Controller



When using powerful Titan operating system;  
Dual core processor, 60g SSD drive, 2 gb of memory;  
To support Chinese menu display and built-in multiple languages;  
Have a built-in 15.4 inch touch screen.  
And can be extended a 17-inch touch screen;  
When four DMX output port,2048 DMX channels;  
Does support Artnet and can be extended to 12, DMX output  
6144 channels;10 macro buttons, you can edit any program;  
When 20 replay push rod support 1000 virtual replay;  
Have strong CMY palette function;  
Does support graffiti type written naming functions;  
Support CIP protocol, you can preview server or digital  
modulation of built-in material;  
To set aside an external wi-fi access point, the Ipod Touch  
and iphone can be used for remote control;  
Have built-in library of thousands of lights,  
and built-in lights library editing software;  
Have built-in stage Visualiser visualization simulation  
software, support video;  
To provide the MIDI time code control, remote replay  
button or by MIDI pusher;  
Have built-in pixel map generator and a built-in graphics.  
Net weight:14kg Gross weight:29kg  
Packing Size:750\*610\*200mm

## CW-K192 192 DMX controller



DMX512 single output  
Total 240 channels  
12programs  
40steps  
12computer lights  
16channels/light  
48dimmer channels  
Packing: carton box  
N.W.:4.3kg  
G.W.:5.0kg  
Product Size:49\*24.5\*11cm  
Packaging Size:53\*32\*15cm

# EFFECTOS ESPECIALES

**CW-3000WD**  
3000W/6000W  
Dry Ice Machine



Voltage: AC100-120V  
AC220-240V 50/60HZ  
Power: 3000W/6000W  
Minimum heating time: 10min  
Electronic temperature control: 75° C-85° C  
Water consumption: 10L (reaching the water line)  
Maximum continuous output duration: 3min  
Maximum coverage area: about 100-150m  
Net weight: 10.5KG  
Gross weight: 11KG  
Machine size: 45 \* 26 \* 24cm  
Package size: 49 \* 49 \* 47cm  
Consumables used: columnar/granular dry ice

**CW-3000WV**  
Vertical spray foam  
Machine



Voltage: AC110V/220V50/60HZ  
Power: 3000W  
Material: Iron  
Control mode: power/remote control/manual  
Coverage area: 150 square meters  
Spray distance: 8-15 meters  
Bracket: Removable  
Foam water: 40L/Min  
Net weight: 30KG  
Product size: L120 \* W65 \* H110CM

**CW-3000WS**  
90° - 360° Moving Head  
Spraying Foam Machine



Voltage: AC110V/220V 50-60HZ  
Power: 3000W  
Spray distance: 10-15 meters  
Coverage area: 150 square meters  
Material: Iron  
Mode: power/remote control/manual  
Features: Convenient movement,  
adjustable angle  
Size: 112cm \* 38cm \* 114cm  
Weight: 46KG

**CW-150WC**  
Large Co2 Jet Machine



Voltage: AC220V 50/60Hz  
Power: 150W  
Height edection: 8-10m  
Product size: 350x350x580mm  
Weight: 6kg

**CW-350WB**  
LED Smoke  
Bubble Machine



Voltage: AC110V-240V 50/60Hz  
Power: 3500W  
LED Source: 18pcs 3 in 1 LED  
Control mode: Remote/Timing quantitative  
Warm-up time: 60s  
Capacity of flue gas cylinder: 1L  
Bubble oil capacity: 1L  
Bubble height: 8-10M  
Coverage area: 150-200square meters  
Control mode: LCD screen control,  
DMX512, Remote control  
Product size: 550\*380\*350mm  
Product weight: 13kg

**CW-300WF**  
Large Double Wheel  
Bubble Machine



Adjustable angle: 45° - 90°  
Blowable height: 6-8 meters  
Power size: 300W  
Oil hopper capacity: 2.5L  
Mode: Manual/Remote control  
Weight: 6KG  
Size: 34X43X30.5mm (LxWxH)

**CW-3000WF**  
3000W Fog Machine



Voltage: AC110/230V 50-60Hz ± 10%  
Power: 3000W  
Warm-up Time: 12Min  
Oil smoke capacity: 6L  
Spray distance: 20M  
Smoke covered: 40000cu.ft/min  
Control: Time quantitative/DMX512  
N.W.: 13kg  
G.W.: 14.5kg  
Product Size: 72\*28\*30cm  
Package Size: 76\*34\*35cm

**CW-1500WT**  
1500W Thin Mist  
Haze Machine



Voltage: AC110V 220V-250V 50/60Hz  
Power: 1500W  
Control mode: LCD Display/DMX512  
Warm-up Time: 5Min  
Oil smoke capacity: 2L  
Oil consumption rate (100% Output) : 0.4L/H  
Smoke covered: 8000cu.ft/min  
Size: 55\*28\*27cm  
Weight: 12kg

**CW-1500WL**  
1500W LED Fogger



Voltage: AC110-220V 50-60Hz  
Power: 1500W  
Source: 9pcs 3W RGB LED  
Control: DMX512, Wireless remote control  
Warm-up time: 5 minutes  
Tank capacity: 2.3L  
Fluid consumption: 18000 Cuft/Min  
Smoke distance: 4-5m  
Size: 510\*210\*230mm  
Weight: 5KG

**CW-1200WE**  
LED Electric Blower  
Confetti Machine



Voltage: AC110V-220V 50-60Hz  
Power: 1200W  
Control mode: DMX and Remote  
Source: 12pcs 3W LED  
DMX Channel: 1CH  
Loading of confetti: 0.3-0.5kgs  
Continued time: 30S-60S  
Spray height: 8-10m  
Size: 54 x 28 x 28cm  
Weight: 8KG

**CW-20WG**  
LED CO2 Gun



Voltage: 110-220VAC 50/60Hz  
Power: 20W  
Control: By Handle  
Spray Height: 6-7 meters  
Product Weight: 8 Kg Color: +7 Colors Tube  
Product Size: 75x30x22cm

**CW-100WP**  
Co2 Cyclone  
Paper Machine



Voltage: AC90-240V 50-60Hz  
Source: 100W LED COB  
Color: White, Warm white  
Channel: 6CH  
IP Rate: IP65  
Mode: DMX512, master-slave, Auto, Sound  
N.W.: 5.5kg  
G.W.: 6.0kg

# ADICIONALES

**CW-H600**  
Haze Machine



Voltage: AC110V-220V 50/60Hz  
Limiting insurance:5A/250V  
Power:600W  
Tank Volume:3L  
3 Fans angle:Adjustable  
Output of the wind turbine regulation:Support  
DMX-512:Support  
Controller: LCD controller  
Warm time: No,Set-up time  
N.W.:18kg G.W.:30kg  
Product size:46\*32\*30CM  
Packing size:52\*40\*45CM(with flight case)

**CW-YJ1500**  
1500W Fog Machine



Voltage: AC120V/230V 50-60Hz  
Power Consumption: 1500W  
Fuse: 10A  
Tank Capacity: 2L  
Smoke Output: 6500cuft/min  
Warn Up Time: 10min  
Output time: 40-50s  
Output Distance: 10M  
Outline Size: 480x300x220mm  
Packing Size: 550x335x265mm  
N.W.: 6.3kg  
G.W.: 7.5kg

**CW-L1500**  
LED Up Fog Machine



Voltage: AC110-120V/220-240V 50/60Hz  
Current-limited safely device:  
8A/250V 15A/250V  
Power:1500W  
Source:24pcs RGB LED  
Warm-up Time: 5Min  
Smoke covered:4000cuft/min  
Oil smoke capacity:2.5L  
Oil consumption rate:8min/L  
Control:W-4 Wireless controller  
No-oil protection: Support  
Channel: 9CH

**CW-600W**  
Sparkular Machine



Voltage: AC220V 50-60Hz  
Power: 420W,2.8A  
Spray height: 3-3.5m for large consumables  
Medium consumables 2-2.5m  
Spray direction: Up and Up  
Operating temperature: -10°C-50°C  
Preheating time:3-5min  
Interface type: Double DMX interface,  
Double AC power interface  
Mode: Wireless control, Standard DMX signal  
Size: 190\*184\*245mm  
Weight: 5.5kg

**CW-L3000**  
3000W Low Fog Machine



Voltage:AC110V-220V 50/60Hz  
Current-limited safely device:15A/250V  
Power:3000W  
Capacity of oil tank:10L  
Warm-up Time:5Min  
Oil consumption rate:6min/L  
Smoke covered:20000cu.ft/min  
Controller:LCD-3 Controller  
DMX Channe:1CH  
Product size:680x500x560mm  
Weight:47kg

**CW-J180**  
LED Co2 Jet Machine



Voltage: AC110V-240 50/60Hz  
Power: 180W  
LED Source:18pcs\*3W RGB 3in1  
Column height: 8 meters  
Smoke coverage: 20000cu.ff/min  
Control: DMX512  
Channel: 7CH  
N.W.: 7.7KG  
G.W.: 11KG  
Packing Size:45\*42\*46cm

Flight case



Glass ball



Safety rope



Light hook



Light support



Light source



Spray Powder



Smoke fluid



# RUEDAS TRUSS

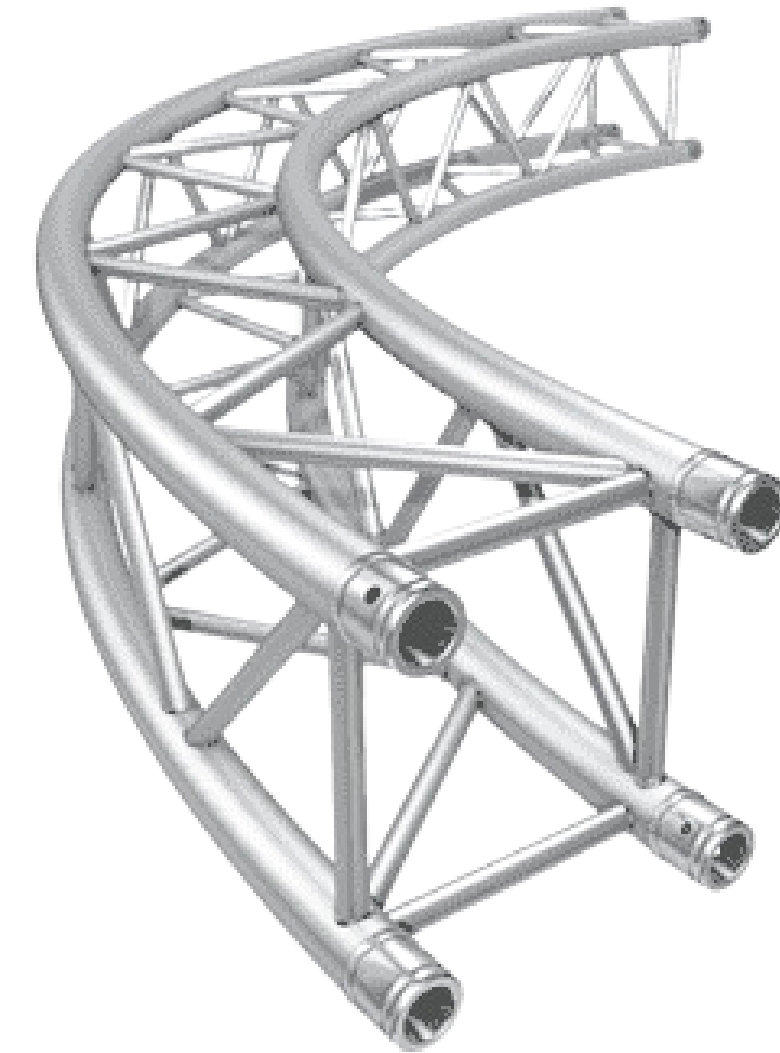
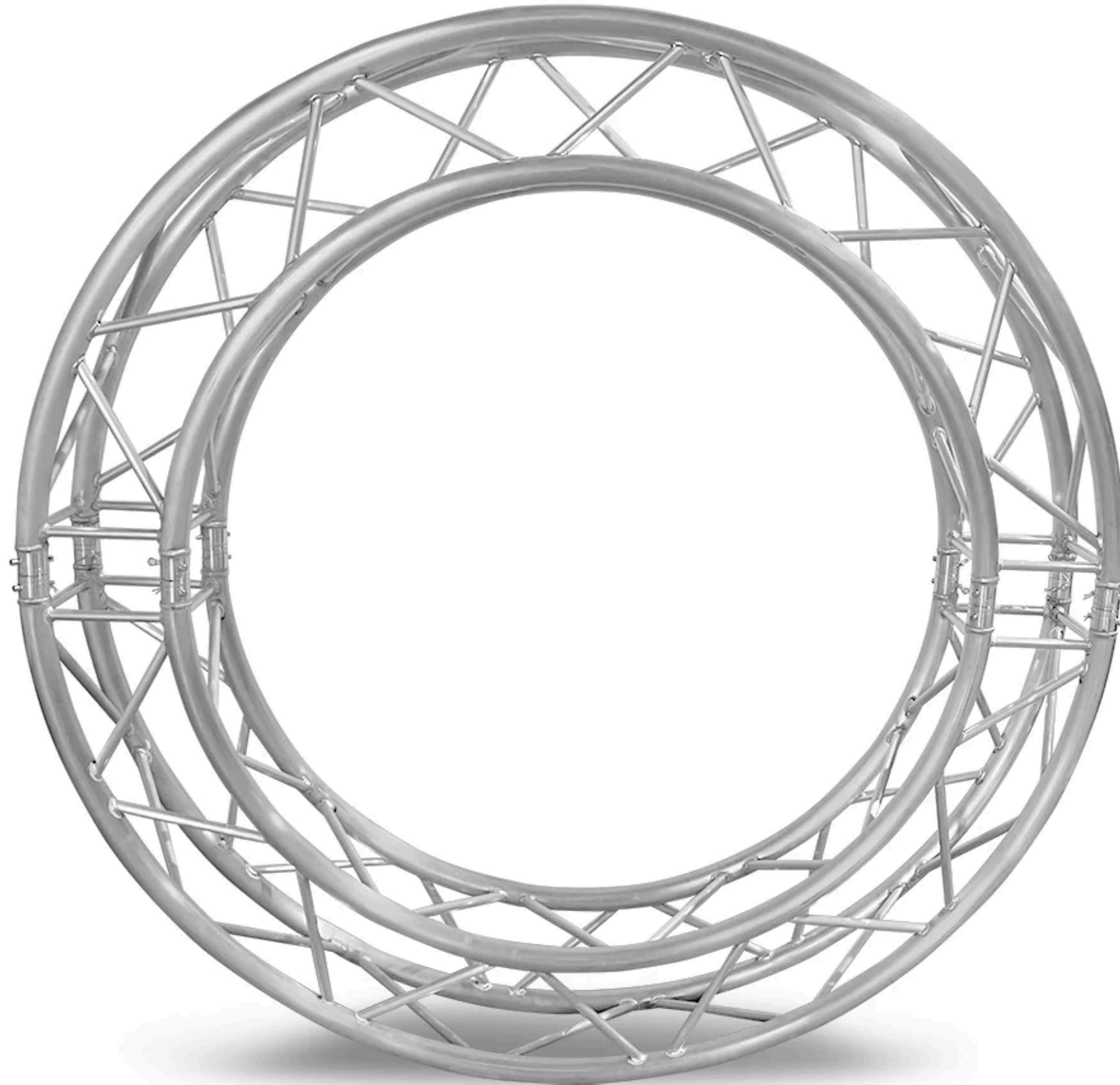

## Medidas disponibles

- Rueda de 2 mts
- Rueda de 3 mts
- Rueda de 4 mts

# FIGURAS TRUSS

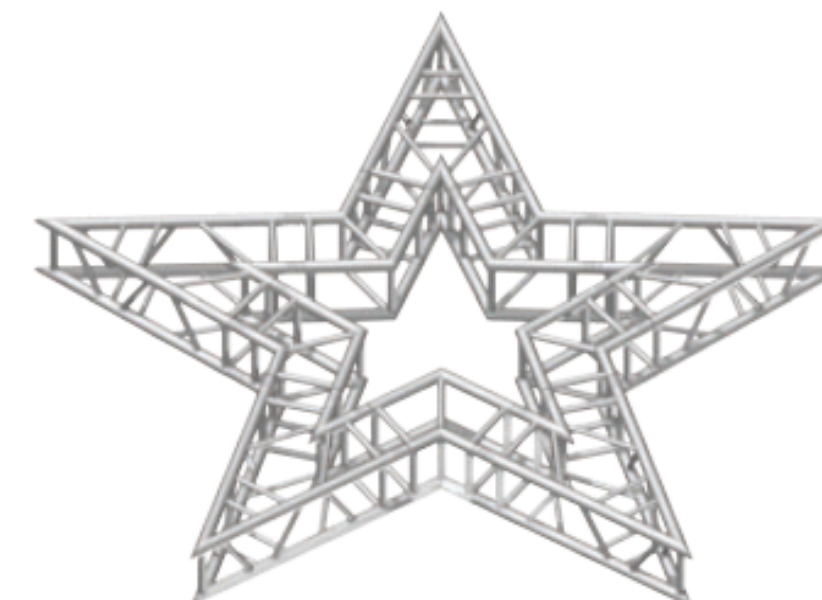
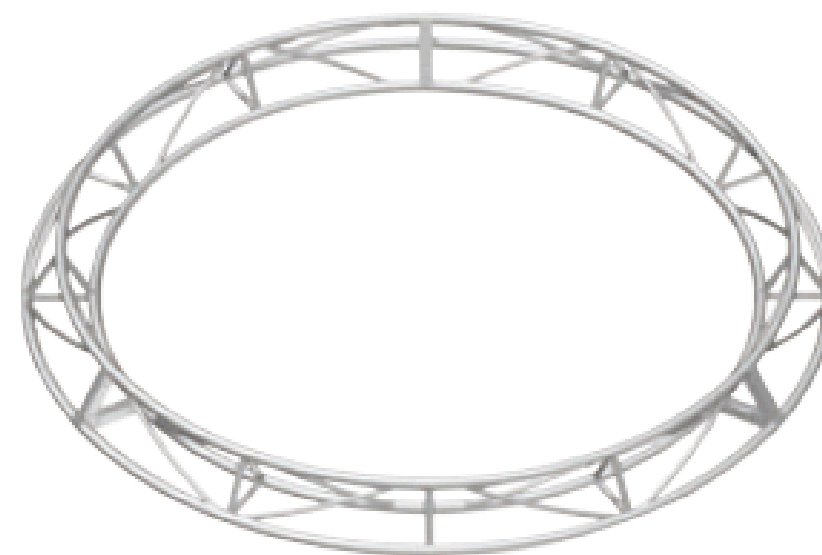
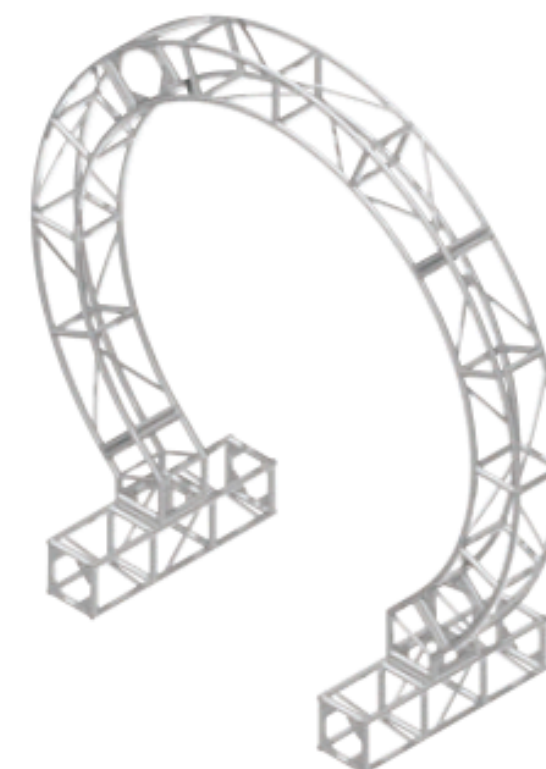
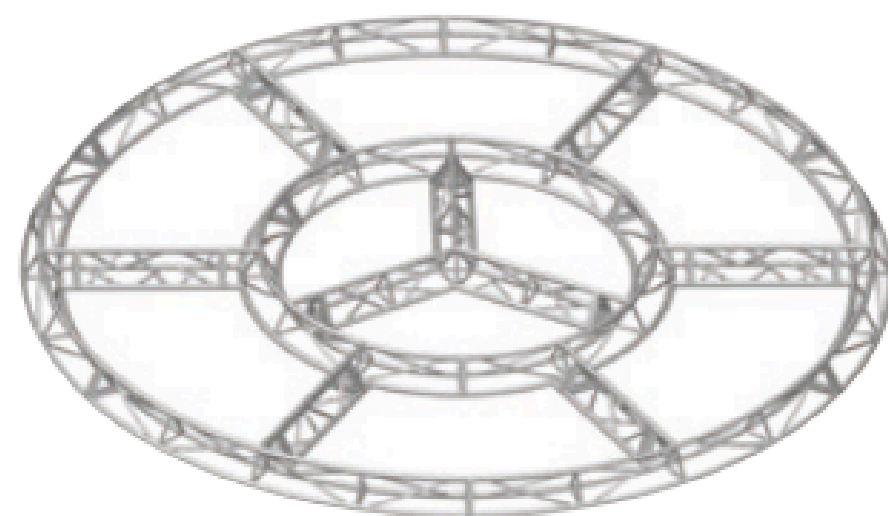
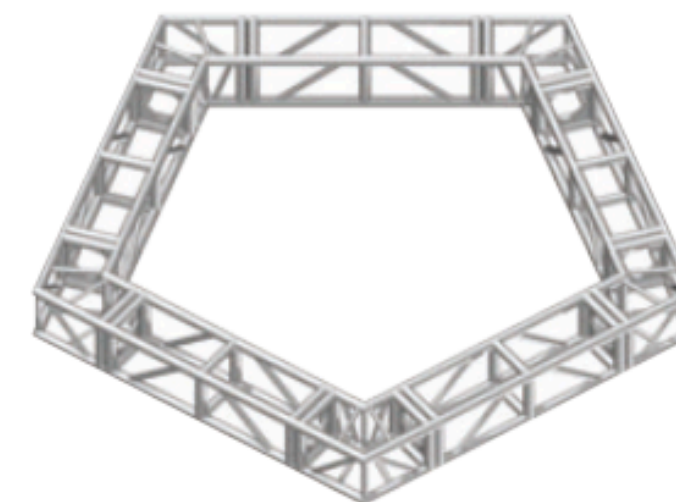
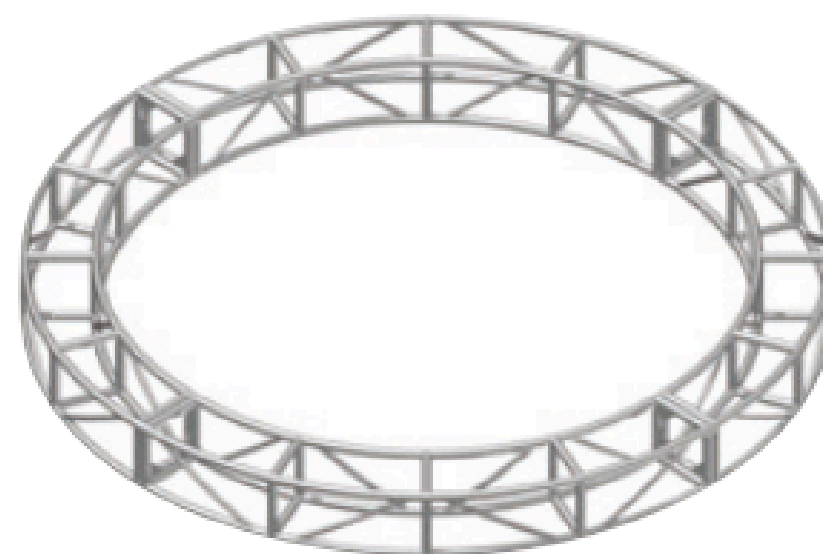
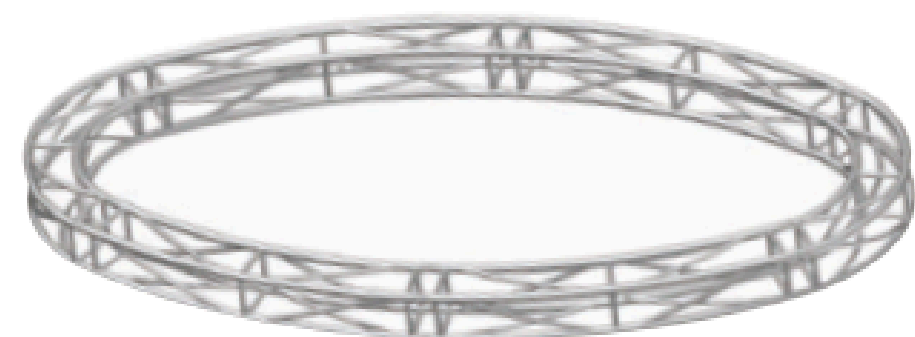

## ESTRUCTURA TRUSS

Truss de 30" en las siguientes medidas:

- Truss de 3mts
- Truss de 2mts
- Truss de 1mts
- Truss de 50cm
- Truss de 25cm

Truss de 40" en las siguientes medidas:

- Truss de 3mts
- Truss de 2mts
- Truss de 1mts

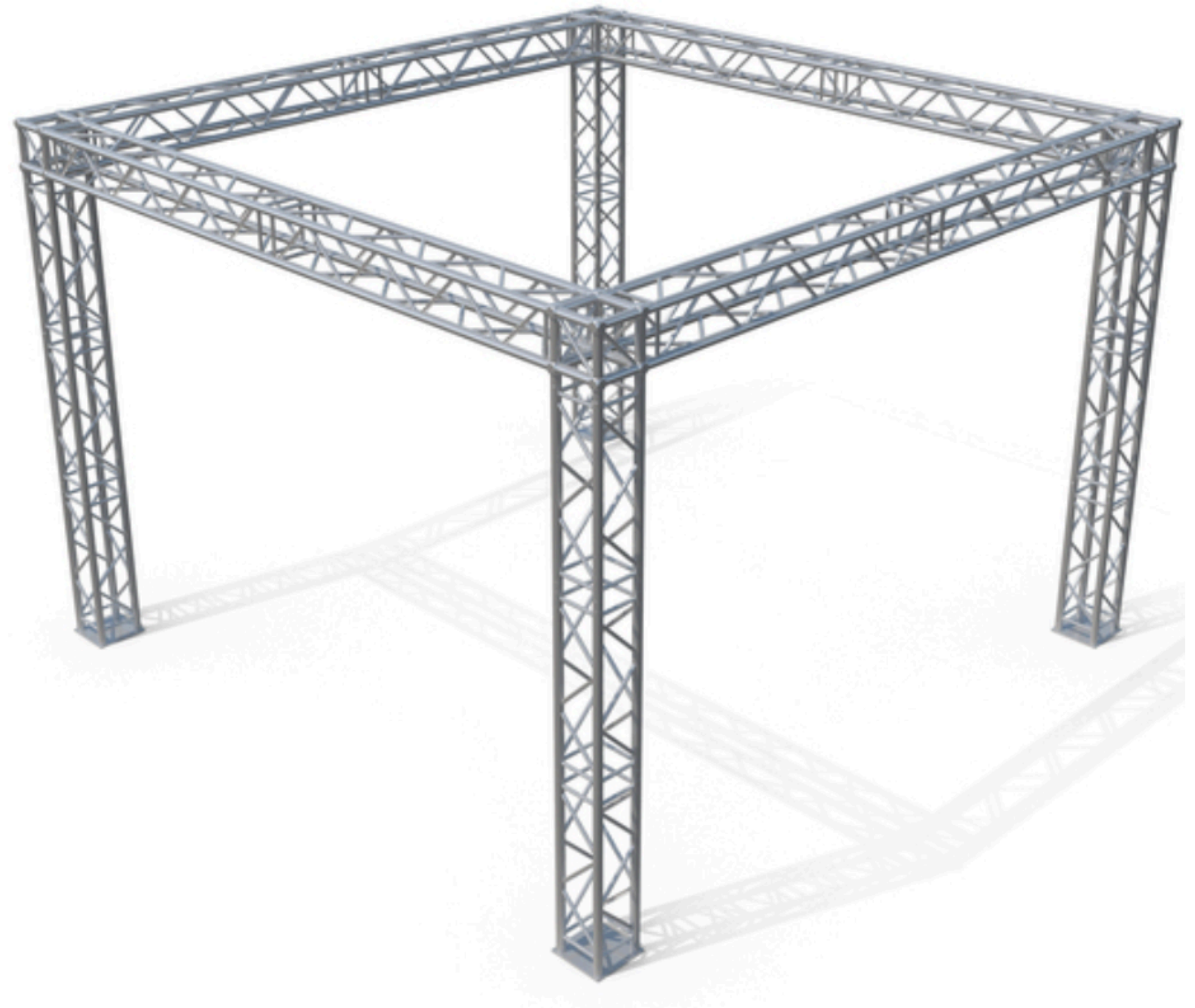



# ESTRUCTURA TRUSS

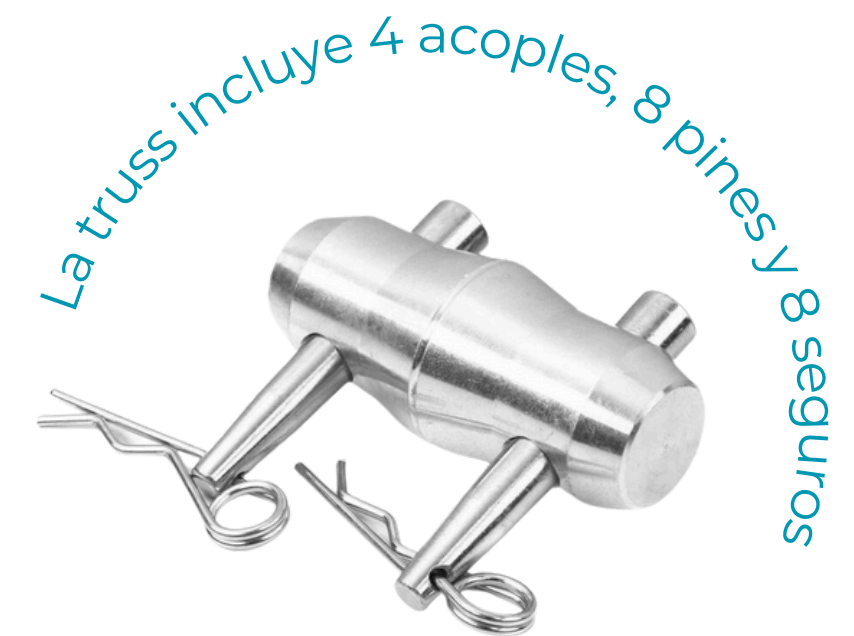
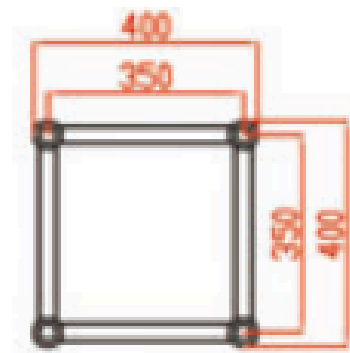
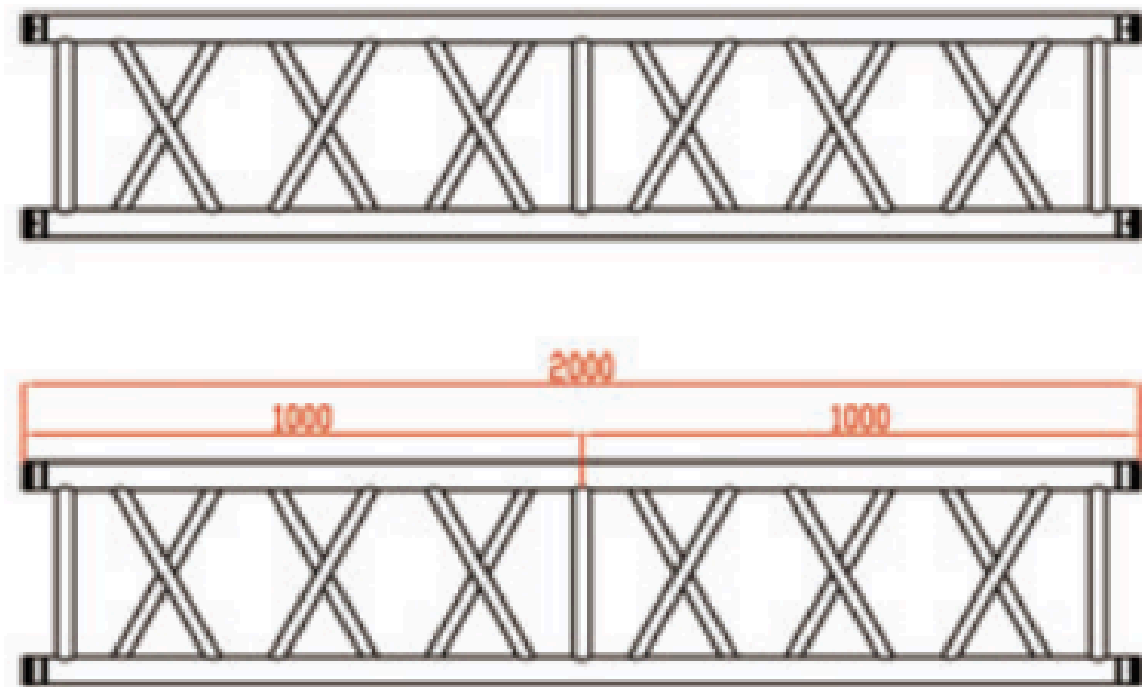
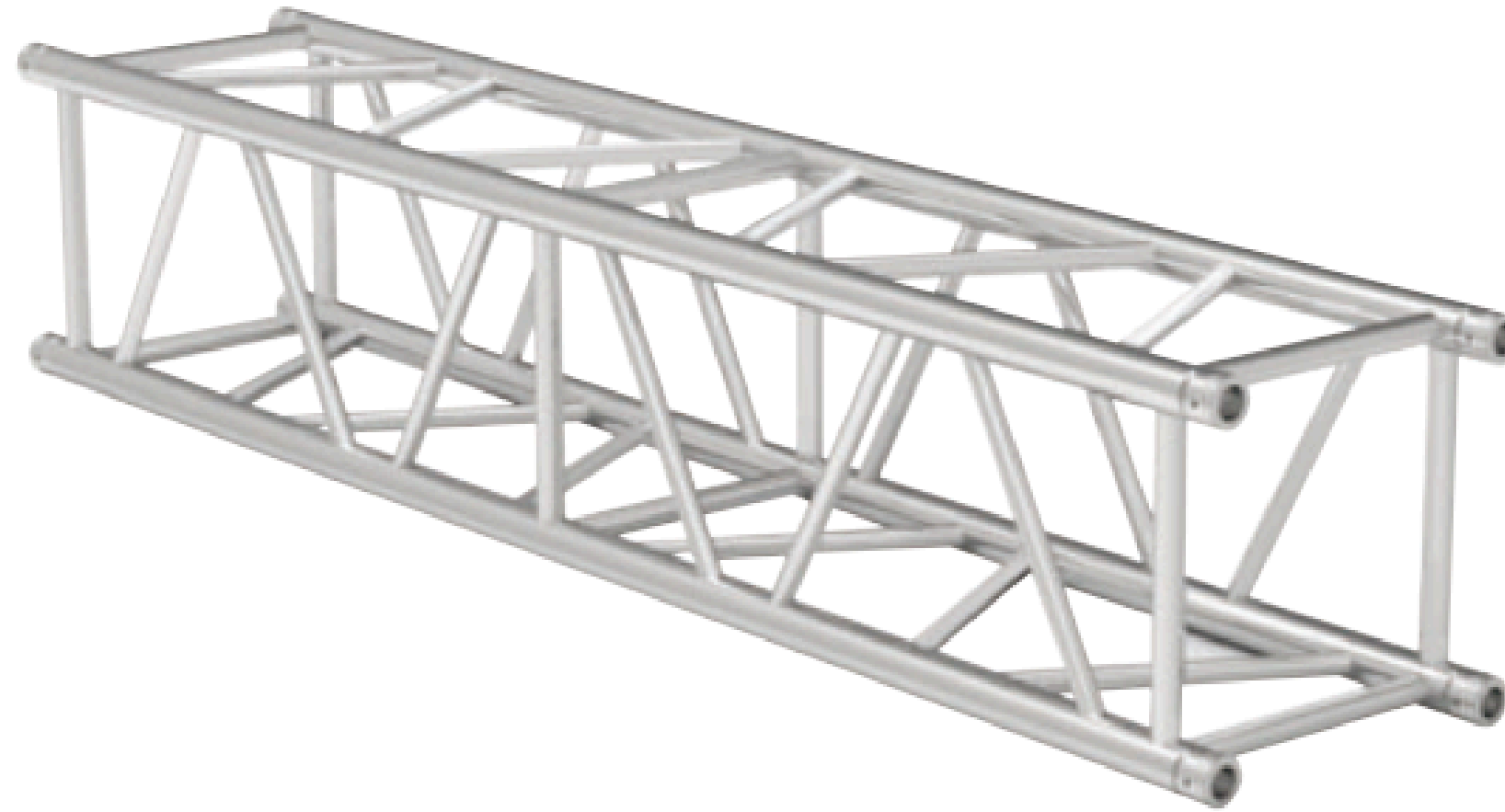

# ESTRUCTURA TRUSS

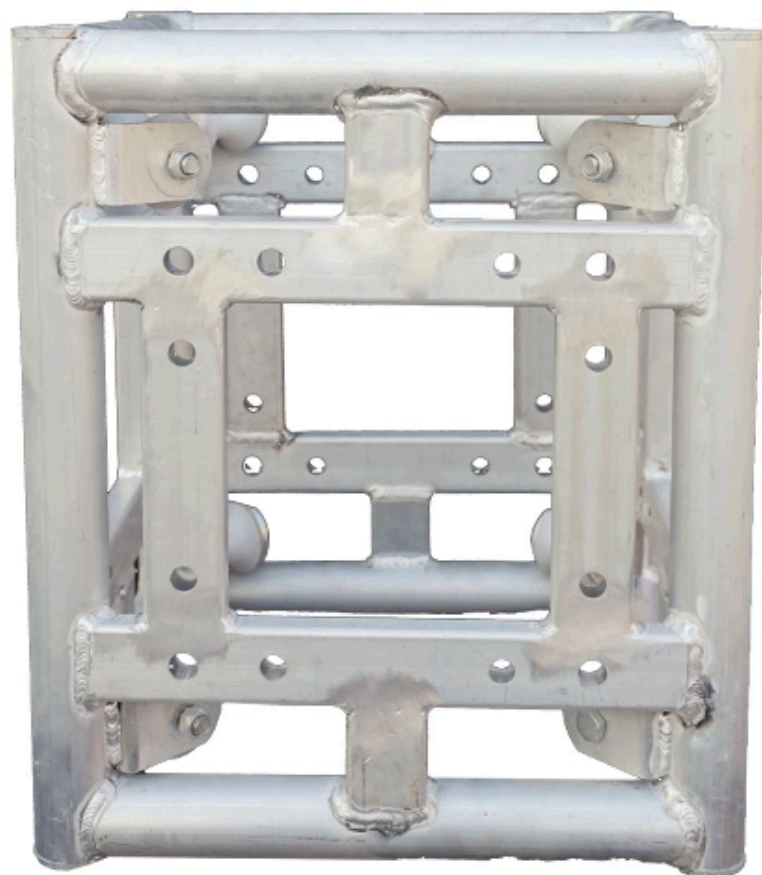

Cubos de diseño

Yoyos elevadores de 30"  
Yoyos elevadores de 40"

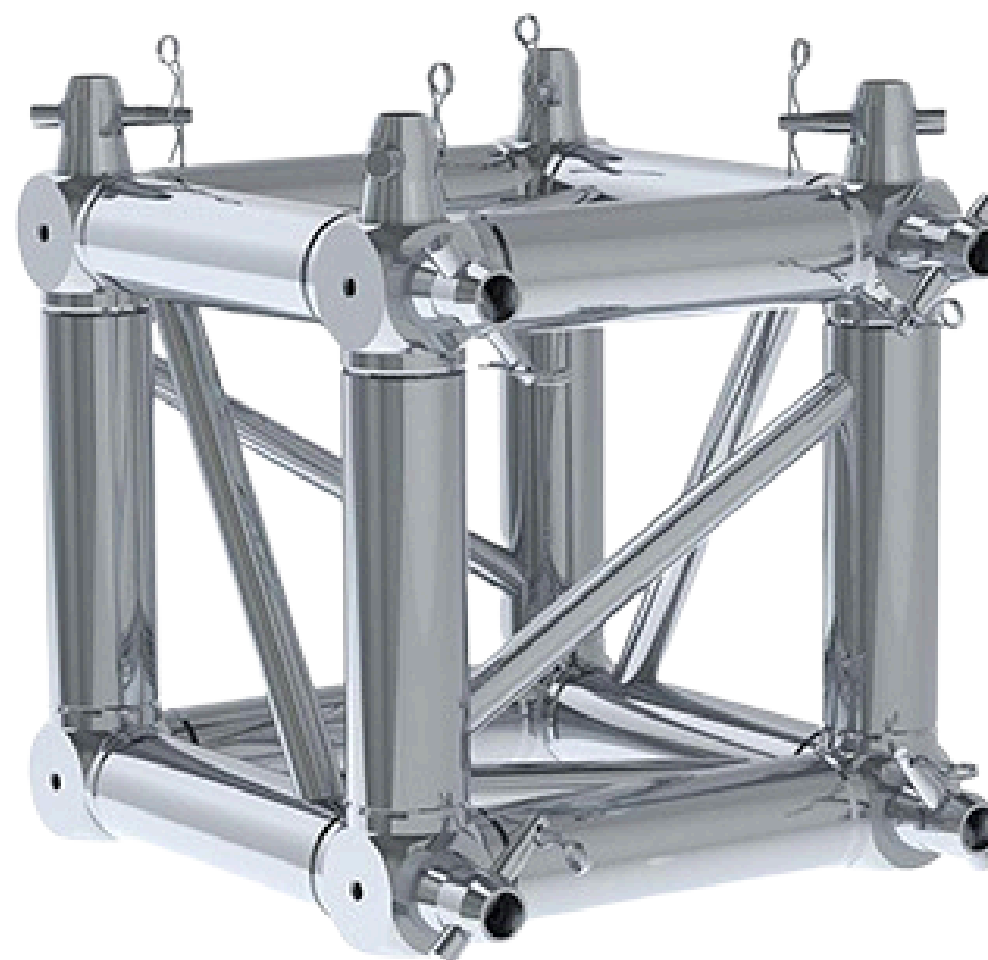

# CONECTORES TRUSS



# BASE TRUSS



Platinas

Zapatas

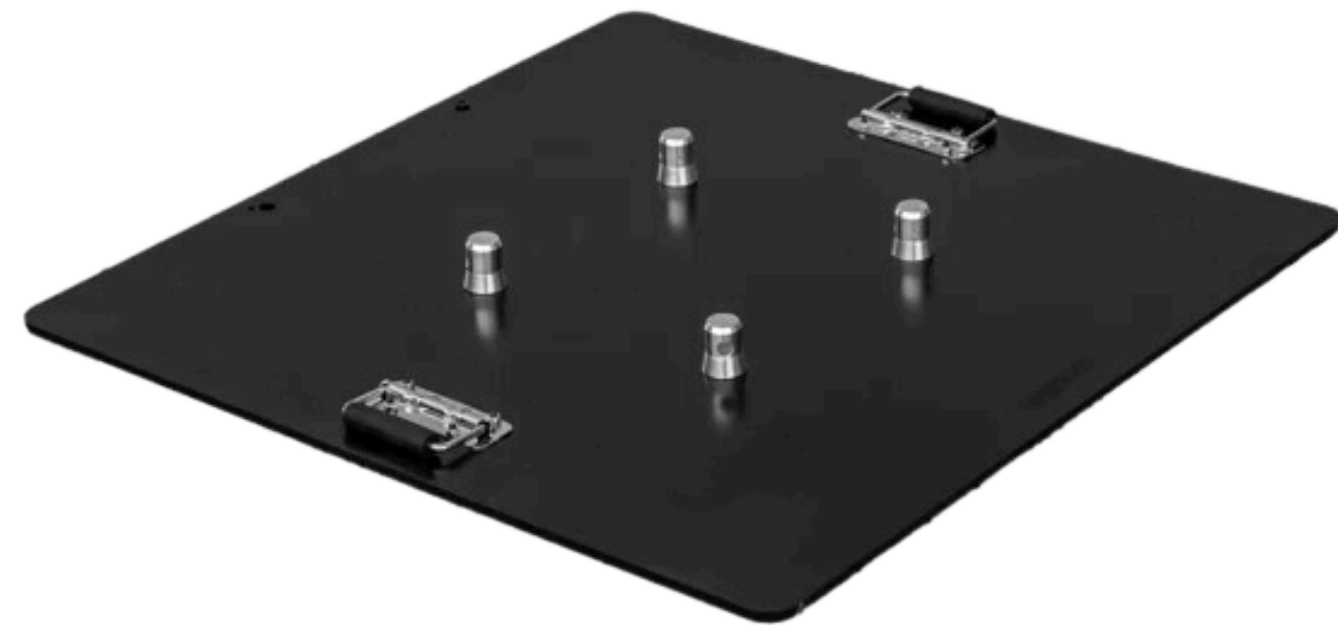

# ACCESORIOS

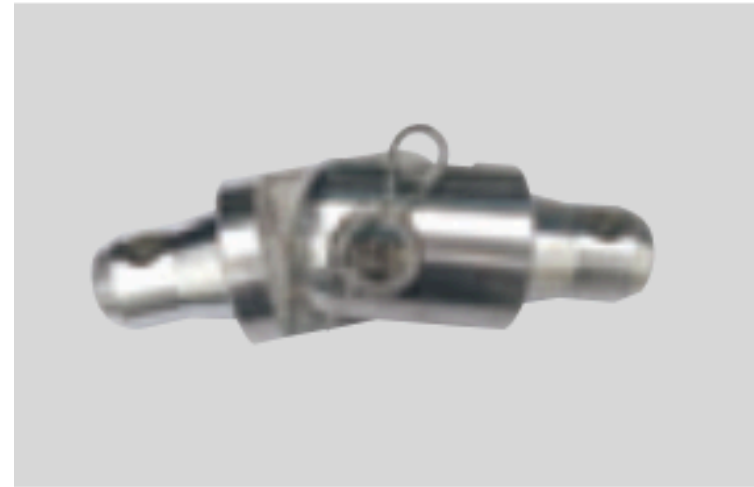
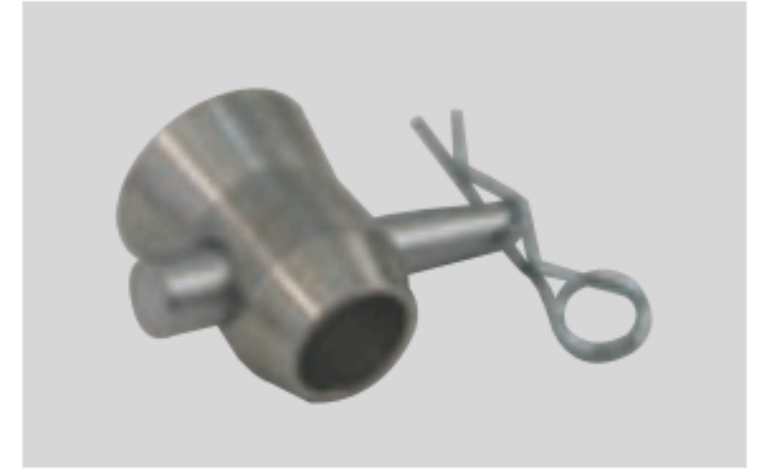

# ACCESORIOS

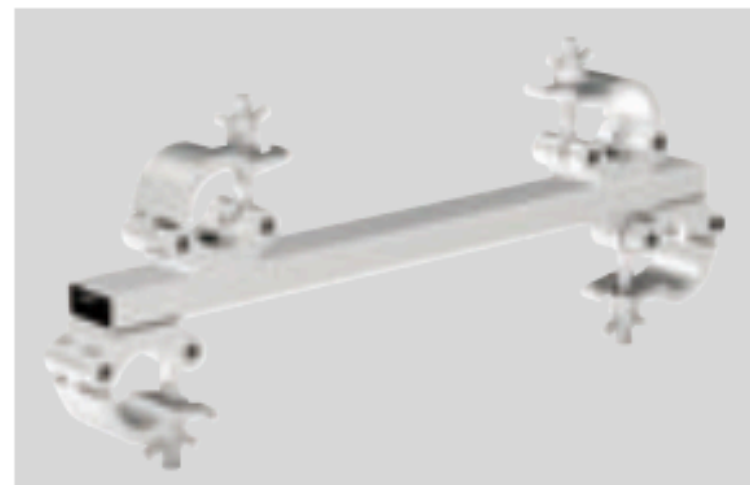

# MÓDULOS DE TARIMA

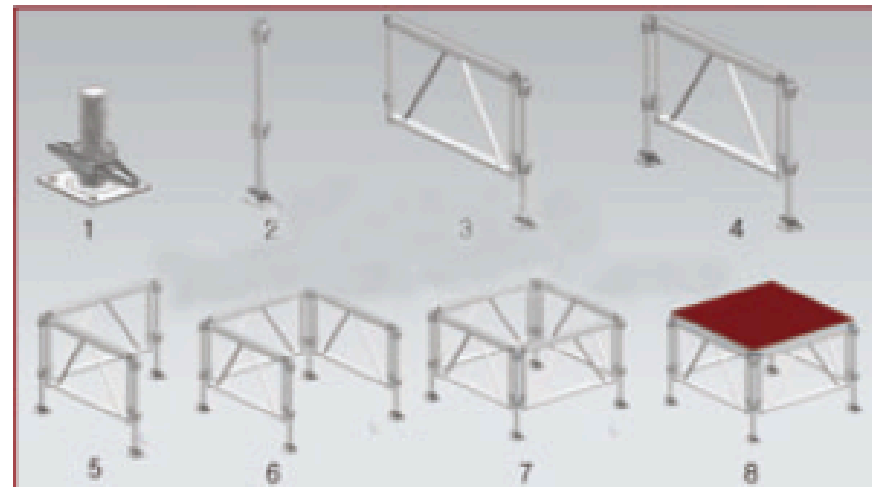
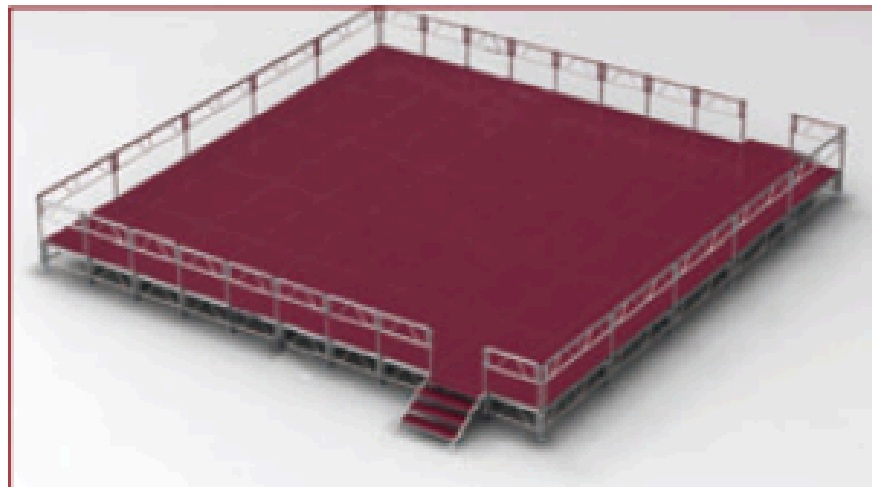
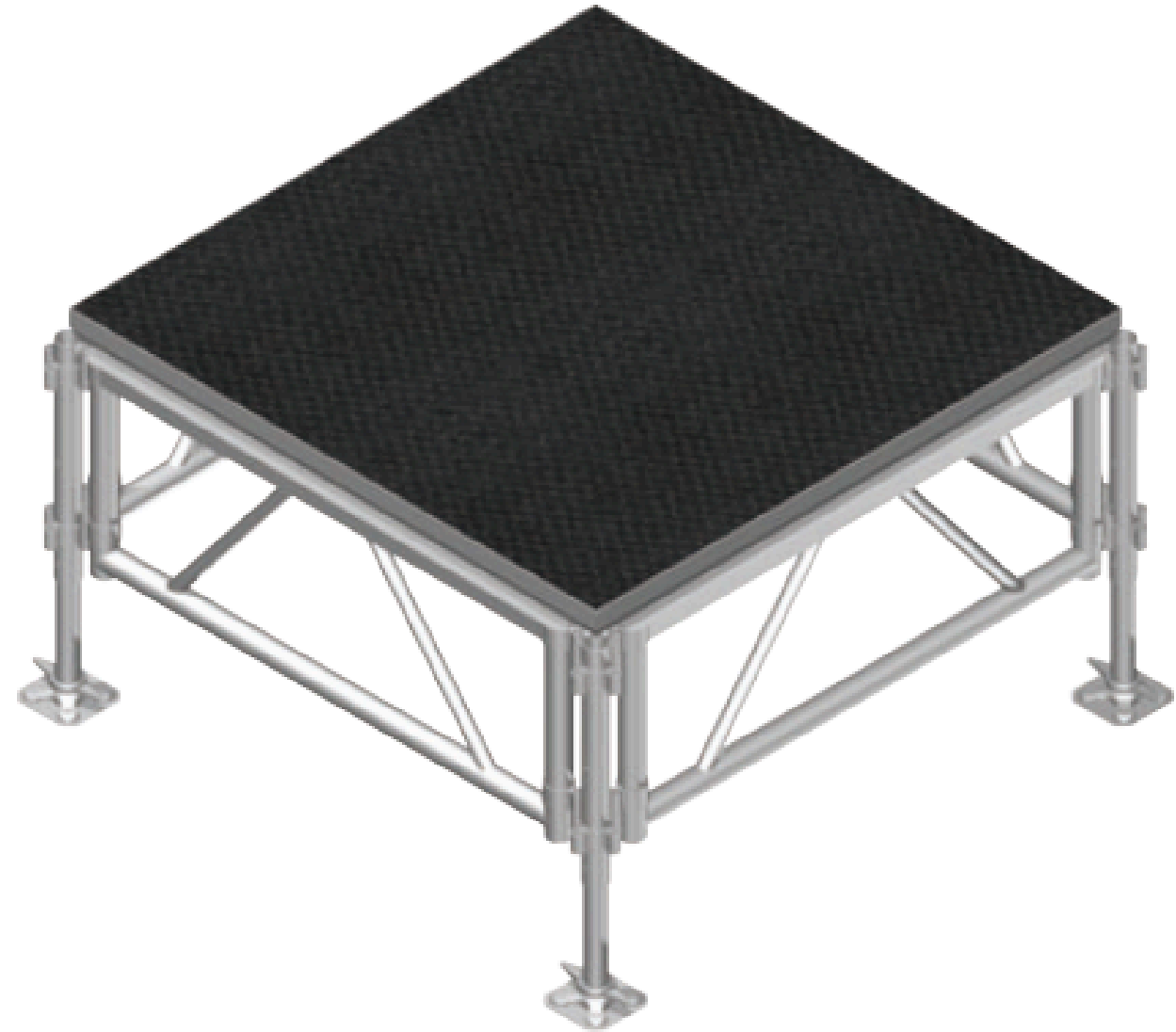

# MÓDULOS DE TARIMA

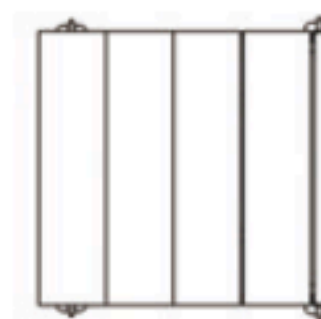
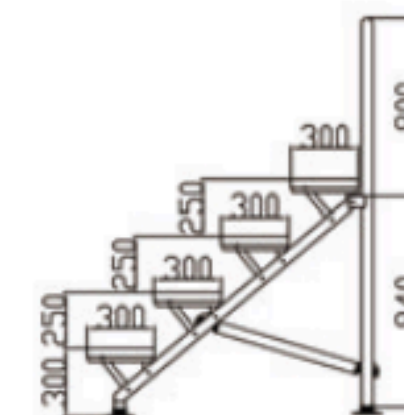
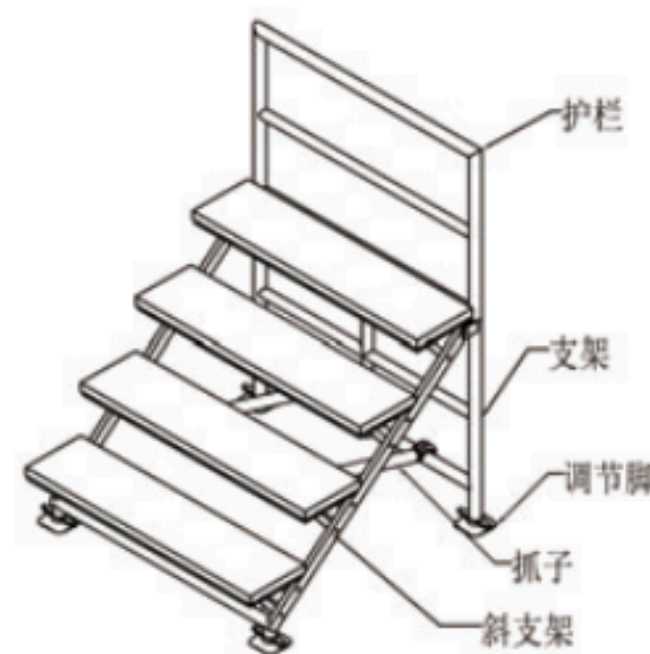
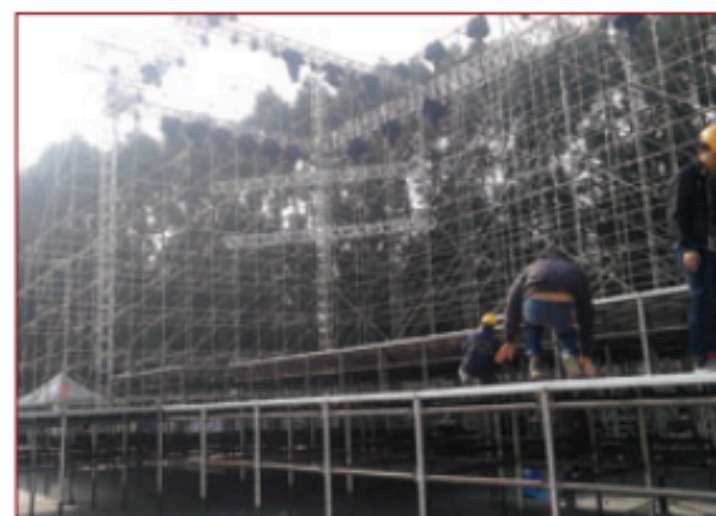
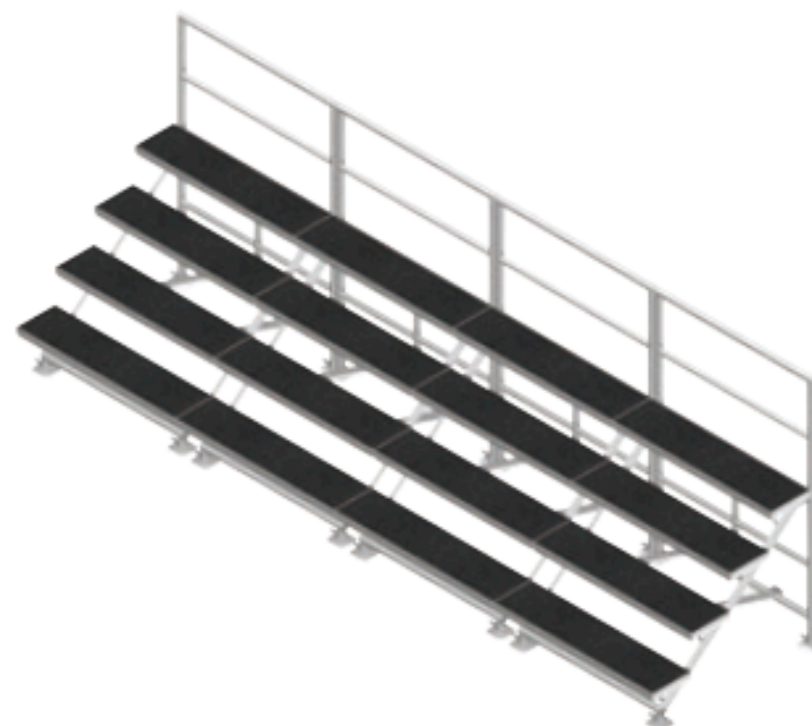



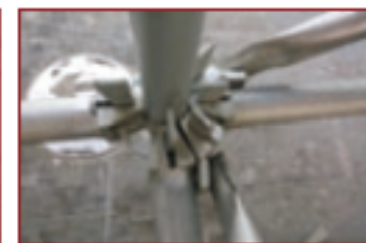
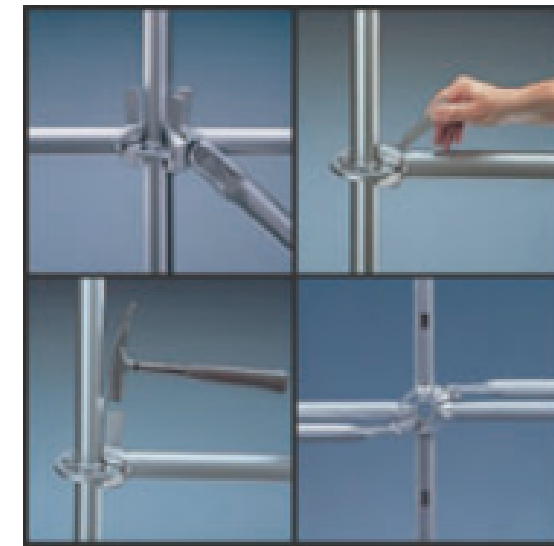
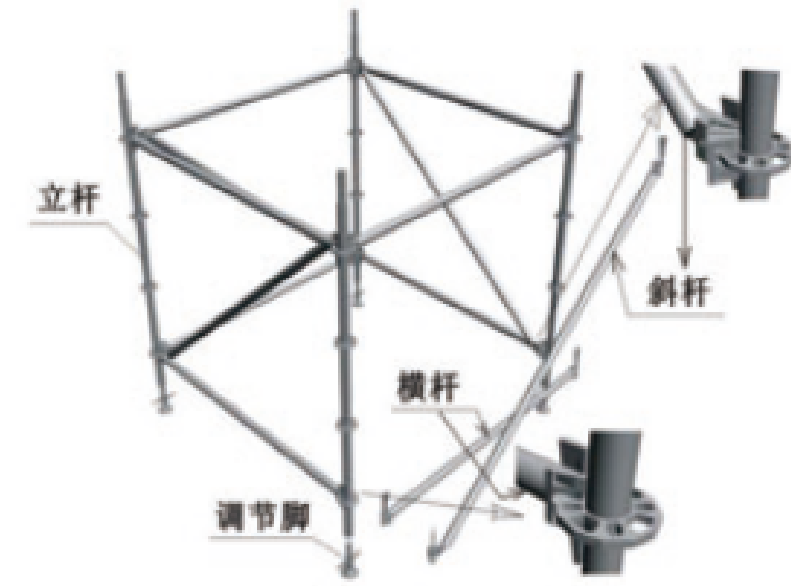
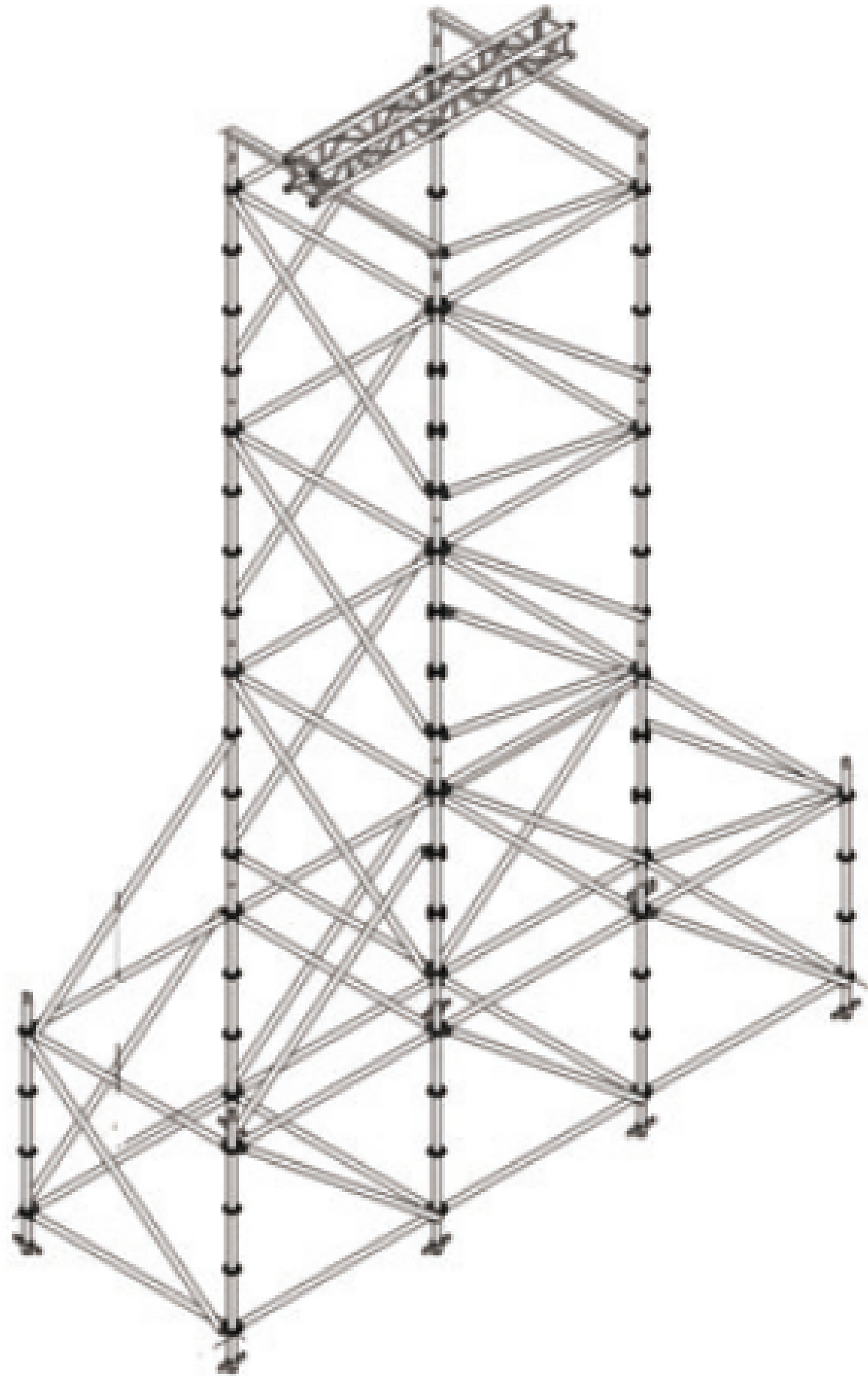

# POLIPASTO

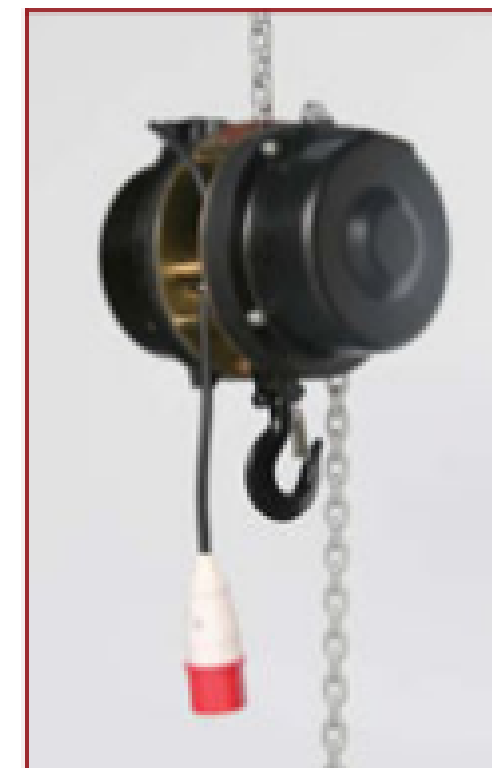

# BARRICADAS

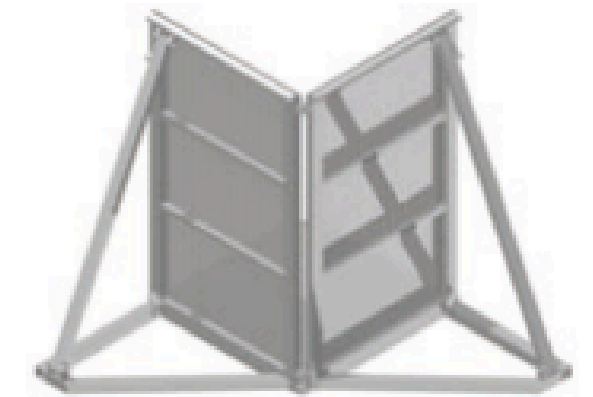
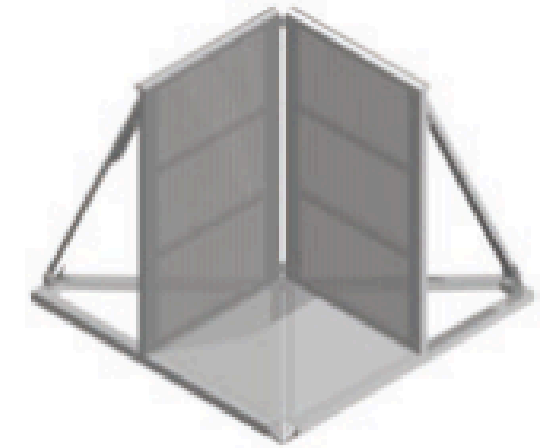
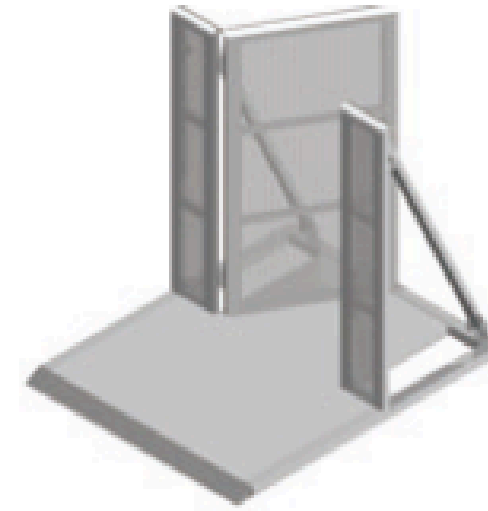
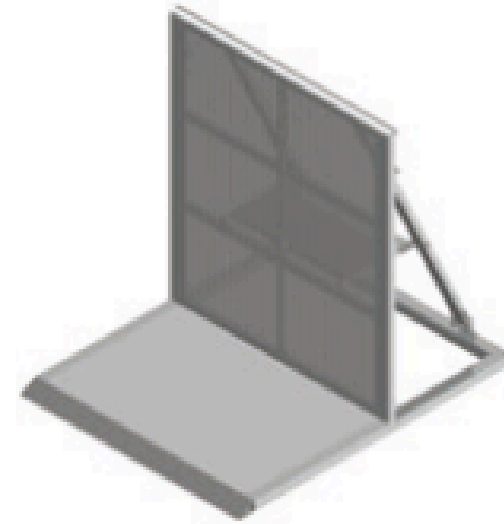

# PASACABLES

